

## *PNEUMATIC TOOLS*

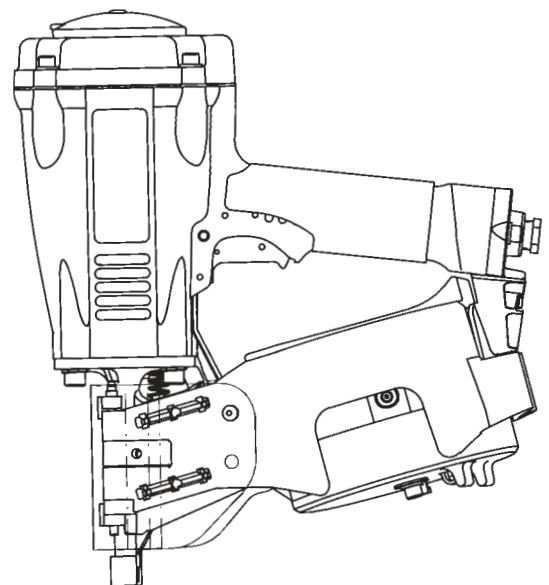
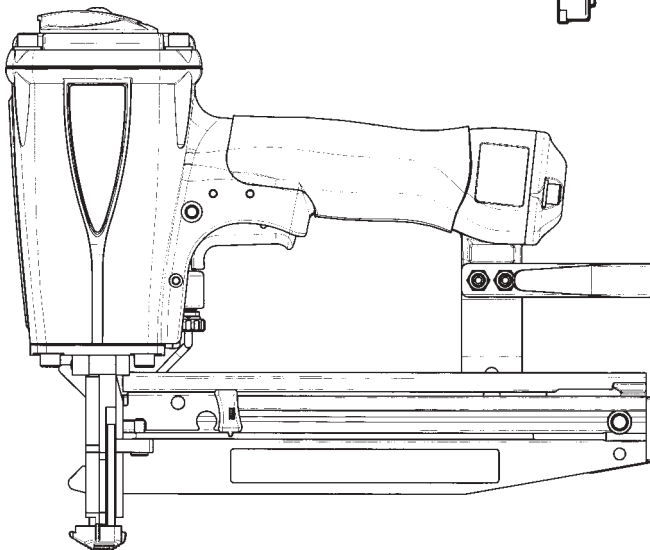
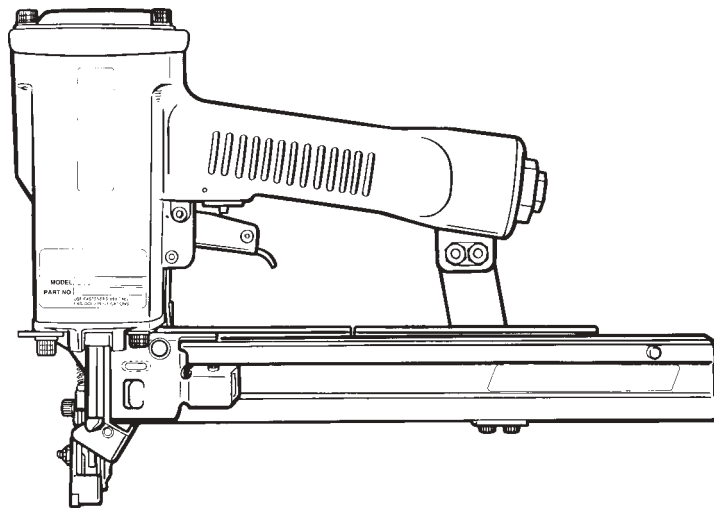
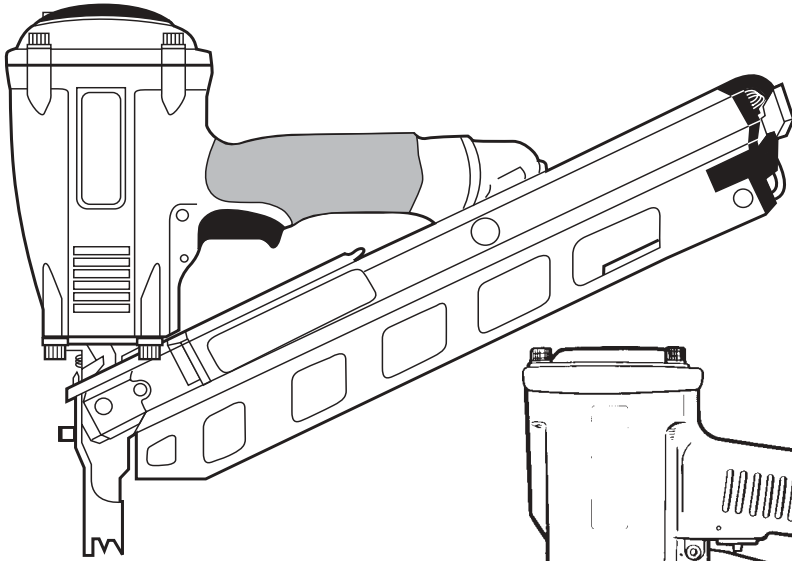

## Operating and Maintenance Manual

## PASLODE MODEL NUMBER DESIGNATION

The model number of each Paslode tool contains information about the tool and the fasteners that are used with it. The following example illustrates the information contained in this tool model number.

**NAILER**

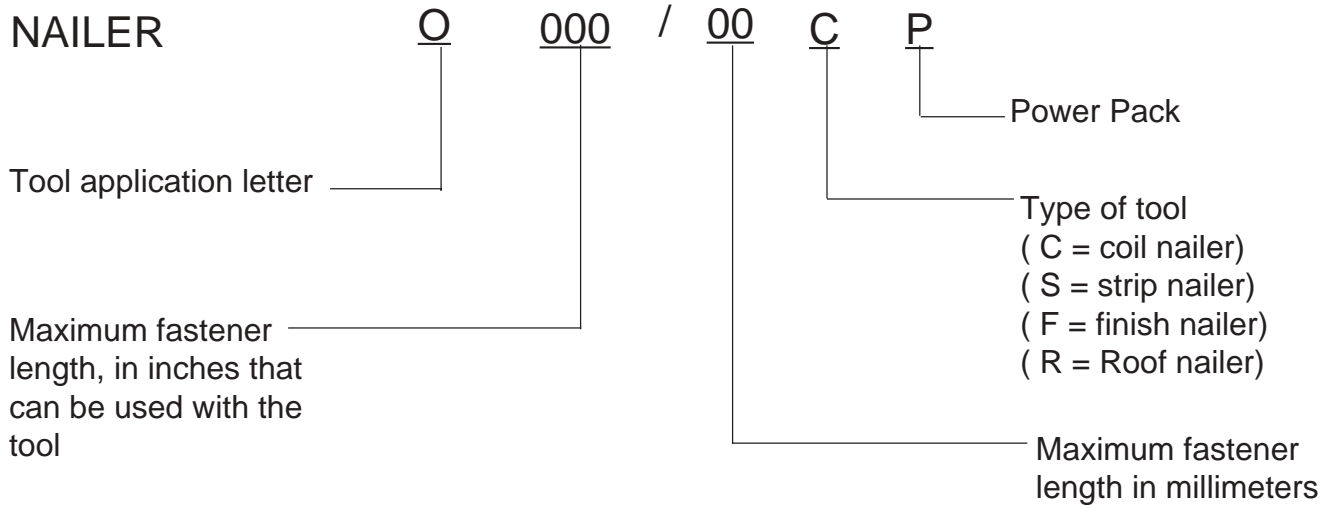

**STAPLER**

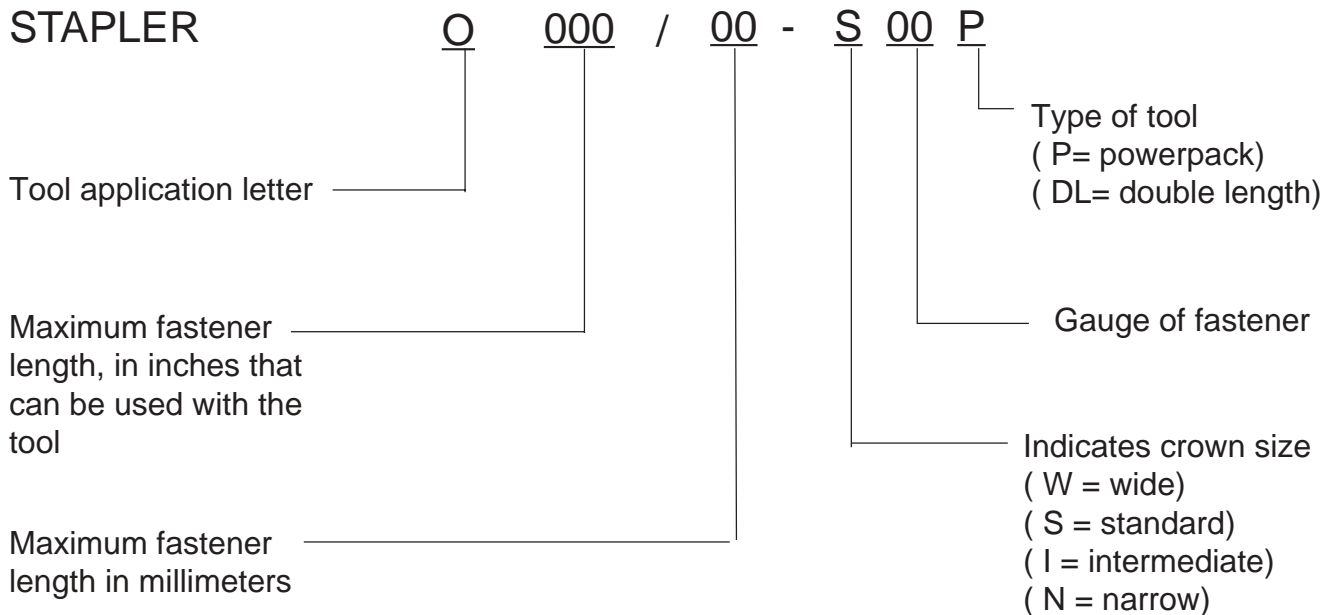

Paslode is a member of:



# INTRODUCTION

Congratulations on purchasing a Paslode pneumatic tool. You have made a wise choice.

A Paslode tool is a professional quality tool that combines power and speed in a light weight design for versatile operation in a variety of industrial and construction applications.

Please take the time to review this entire manual and all other documentation that came with the tool. They will help you to become familiar with operating a power fastening tool. Be sure to read the safety instructions carefully before using your new tool. Also read Paslode's warranty statement in the back of this manual.

Even though Paslode is a leader in the power fastening business, we continually strive to find new and better ways of improving our products. That is a commitment we've made to our most important asset: our customer.

Paslode also manufactures a line of cordless tools featuring Impulse Technology, which are not covered in this manual. For maintenance and safety information on the line of cordless tools, consult the operating manuals for those tools.

## TABLE OF CONTENTS

<b>INTRODUCTION.....</b>	<b>1</b>
<b>SAFETY INSTRUCTIONS.....</b>	<b>2</b>
<b>AIR SYSTEMS.....</b>	<b>3</b>
<b>TOOL INSTALLATION.....</b>	<b>5</b>
<b>TOOL OPERATION.....</b>	<b>5</b>
<b>TOOL LOADING.....</b>	<b>6</b>
<b>MAINTENANCE.....</b>	<b>9</b>
<b>OPERATOR TROUBLESHOOTING.....</b>	<b>12</b>
<b>TOOL WARRANTY.....</b>	Inside Back Cover

# SAFETY INSTRUCTIONS

## SAFETY FIRST

These safety instructions provide information necessary for safe operation of Paslode® tools. **DO NOT ATTEMPT TO OPERATE THE TOOL UNTIL YOU READ AND UNDERSTAND ALL SAFETY PRECAUTIONS AND MANUAL INSTRUCTIONS.**



### WEAR EYE AND HEARING PROTECTION

Always wear hearing and eye protection devices, including side shields, when operating or working in the vicinity of a tool.

### THE TOOL MUST BE USED ONLY FOR THE PURPOSE FOR WHICH IT WAS DESIGNED

Do not throw the tool on the floor, strike the housing in any way or use the tool as a hammer to knock material into place.

### NEVER ENGAGE IN HORSEPLAY WITH THE TOOL

The tool is not a toy so do not use it like one. Never engage in horseplay with the tool or point it at yourself or any other person, even if you think it is not loaded.

### NEVER ASSUME THE TOOL IS EMPTY

Check the magazine for fasteners that may be left in the tool. Even if you think the tool is empty or disconnected, never point it at anyone or yourself. Unseen fasteners could fire from the tool.

### NEVER CLAMP THE TRIGGER IN A LOCKED OR OPERATING POSITION

The trigger of the tool must never be tampered with, disabled or clamped in a locked or operating position since this will cause the tool to drive a fastener any time the work contacting element depressed.

### DO NOT LOAD FASTENERS WITH THE AIR LINE CONNECTED, OR WITH THE TOOL TRIGGER OR WORK CONTACTING ELEMENT DEPRESSED

When loading fasteners into the tool be sure you disconnect the air line and that you do not depress the trigger or work contacting element.

### OPERATE THE TOOL ONLY ON A WORKPIECE

The tool should be operated only when it is in contact with the workpiece. Even then you should be careful when fastening thin material or working near the edges and corners of the workpiece since the fasteners may drive through or away from the workpiece.



### DO NOT DISABLE OR REMOVE THE WORK CONTACTING ELEMENT

This tool is equipped with a safety mechanism, called a work contacting element, to help prevent accidental firing. Never tamper with, disable or remove the work contacting element. Do not use the tool unless the work contacting element is working properly. The tool could fire unexpectedly.

### DISCONNECT THE TOOL WHEN NOT IN USE

Always disconnect the tool from the air line when it is not

in use or when you leave the work area. The tool should never be left unattended because people who are not familiar with the tool might handle it and injure themselves or others.

### CARRY THE TOOL ONLY BY THE HANDLE

Always carry the tool by the handle only. Never carry the tool by the air hose or with the trigger depressed since you could drive a fastener unintentionally and injure yourself or someone else.



### DO NOT WEAKEN THE TOOL HOUSING

The tool housing is a pressure vessel and should never be weakened by having your company's name, area of work or anything else stamped or engraved into its surface.

### DISCONNECT THE TOOL WHEN PERFORMING REPAIRS AND CLEARING JAMS

Never attempt to clear a jam or repair a tool unless you have disconnected the tool from the air line and removed all remaining fasteners from the tool.

### ALWAYS USE THE PROPER FITTING FOR THE TOOL

Only MALE pneumatic type air connectors should be fitted to the tool, so that high pressure air in the tool is vented to atmosphere as soon as the air line is disconnected.

NEVER install FEMALE quick disconnect couplings on the tool. Female couplings will trap high pressure air in the tool when the air line is disconnected, leaving the tool charged and able to drive at least one fastener.

### DO NOT EXCEED THE MAXIMUM RECOMMENDED AIR PRESSURE

Operate the tool only at the recommended air pressure. Do not exceed the maximum air pressure marked on the tool. Be sure the air pressure gauge is operating properly and check it at least twice a day.



Never use any bottled air or gases such as oxygen to operate the tool since they could cause the tool to explode.

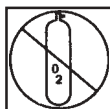

### KEEP THE TOOL CLEAN AND LUBRICATED

Clean the tool at least daily and lubricate as required. Never operate a dirty or malfunctioning tool.

### USE ONLY PASLODE RECOMMENDED PARTS AND FASTENERS

Use only parts and fasteners specifically designed and recommended by Paslode for use in the tool and for work to be done. Using unauthorized parts and fasteners or modifying the tool in any way creates dangerous situations. Replace all missing warning labels---refer to tool schematic for correct placement and part number.

## WARNING

Failure to follow any of the above instructions could result in severe personal injury to tool user and bystanders or cause damage to tool and property.

Contact your local Paslode Representative for presentation of Paslode's Safety Awareness Program

# AIR SYSTEMS

For air-powered tools to work their best, the air supply system must be properly installed and maintained regularly. A drawing in this section shows a properly installed air supply system. Handy checklists for installing and maintaining air supply systems follow.

## Indoor Air System Installation -Be certain that:

- All pipes supplying air have a large enough inside diameter to ensure adequate air supply.
- The main supply pipe slopes down, away from the compressor (1/16 inch per foot).
- Air storage is provided along lengthy air lines.
- Pipe line branch outlets are at the top of the main pipe line.
- Cutoff valves are provided at each branch pipe line throughout the system.
- Water legs extend from the bottom of each branch line.
- A refrigerant-type dryer is installed on the system.
- Air hoses are kept as short as practical.
- A regular maintenance program is followed.

## Outdoor Air System Installation -Be certain that:

- A moisture trap and a filter/regulator/lubricator are installed at the compressor.
- Air hoses and fittings are large enough so that air flow is not restricted. Minimum hose size is 3/8 inch ID with 1/2 inch ID hose used for any application over 25 feet.

- Air hoses are not longer than 150 feet.
- The air system is lubricated regularly.
- A regular maintenance program is followed.

## Filter/Regulator/Lubricator Units

Filter/regulator/lubricator units that can supply enough air and protection for Paslode tools must meet the following specifications:

- Minimum 3/8 inch NPT port size .
- 50 micron or fine filters.
- Regulated pressure from zero to 120 psi.
- Lubricators designed for low or changing airflow.

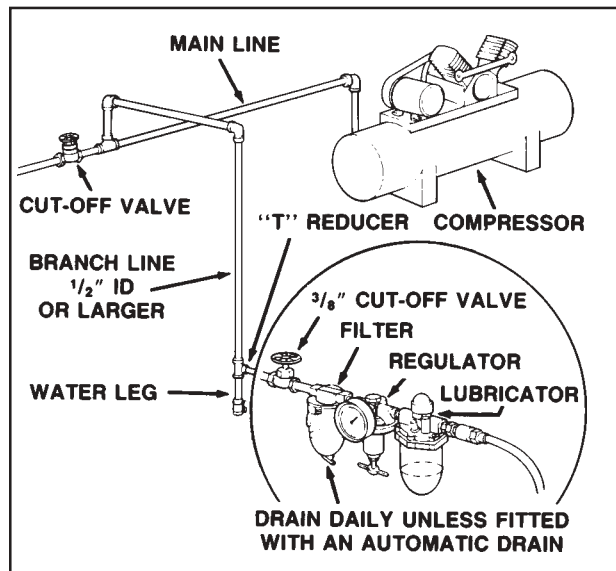

# AIR SYSTEMS - Continued

## Calculating Compressor Size

Use the air consumption chart in the Tool Schematic for each tool when calculating the operating requirements for the tools. Paslode tools are designed to operate efficiently between 80 and 120 psi and should never be operated at pressure greater than 120 psi. The air consumption chart will help you find the correct compressor size for your application that will quickly replenish tool air pressure. To use the chart you will need to know how many tools will be used and approximately how many fasteners will be driven each minute by each tool on the line. Using the equation:

$$\text{Number of tools} \times \text{average fasteners/minute/tool} \times 1.2 \text{ (safety factor)} \times \text{air consumption (scfm) @ pressure* (psi)} = \text{scfm required.}$$

We can use the following example:

$$10 \text{ tools} \times 30 \text{ fasteners/minute/tool} \times 1.2 \times 0.051 \text{ scfm* (@100psi)} = 18.36 \text{ scfm.}$$

\*This number is found in the Air Consumption Chart

In this example, using the air consumption chart we find that a compressor providing at least 19 scfm of air is required. Because in compressors approximately 1 hp is required to produce 4 scfm, a compressor of at least 5 hp is required.

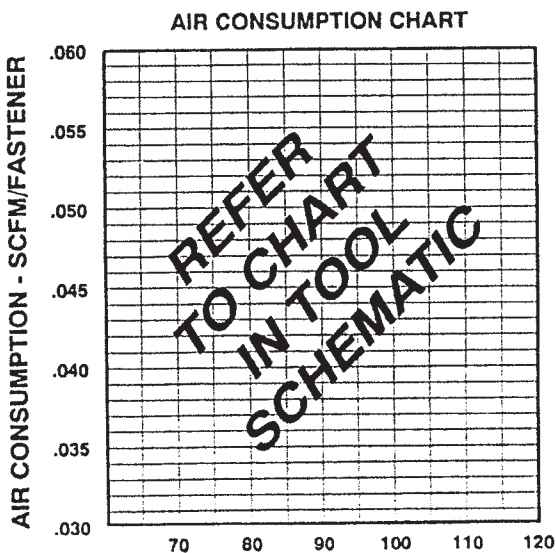

## Calculated Required Piping

For example, given a 20 hp electric compressor supplying approximately 80 cfm of air at 120 psi and a main supply pipe length of 350 feet, we see by the table the minimum main pipe inside diameter required for this application is 1-1/4 inch.

VOLUME OF AIR (CFM)	LENGTH OF RUN (FT.)				
	50-200	200-500	500-1000	1000-2500	2500-5000
NOMINAL PIPE DIAMETER (IN.)					
30-60	1	1	1 1/4	1 1/2	1 1/2
60-100	1	1 1/4	1 1/4	2	2
100-200	1 1/4	1 1/2	2	2 1/4	2 1/2
200-500	2	2 1/2	3	3 1/2	3 1/2
500-1000	2 1/2	3	3 1/2	4	4 1/2

## Pneumatic System Maintenance

### - Be certain that:

- Pneumatic fittings are tight and do not leak.
- Water legs, filters and air lines are drained daily, and ensure that automatic draining systems are operating correctly.
- Air lines are cleared to prevent freezing, especially in winter.
- Lubricator operation is checked regularly and ensure it has an adequate supply of lubricant. (Paslode Part No. 219026)
- The filter element is cleaned every six months.
- Only regulated air is being used and that each regulator is operating properly.

## TOOL INSTALLATION



**DANGER**



**Air pressure at the tool must never exceed 120 psi.**

Your Paslode tool comes ready for immediate use and can be installed by following these steps:

1. **SAFETY** - All tool operators and their immediate supervisors must become familiar with the operator safety instructions before operating the tool. The instructions are on page 2 of this manual.

2. Included with each tool are one copy of this Safety and Maintenance manual and one copy of the Tool Schematic. Keep these publications for future reference. An ownership registration card is also included. This card must be completed and returned to Paslode immediately to register your ownership.

3. The plastic cap in the air inlet of the tool must be removed before the male fitting is installed. The fitting must be a male pneumatic type that discharges the air from the tool when the air line is disconnected.

4. Install a filter/regulator/lubricator unit, with a gauge as close as practical to the tool, preferably within ten feet. Refer to the Air Systems section of this manual for air hose requirements and lengths. In general, no other special installation is required.

5. If the operator is working at a bench or table, it is usually best to run the air line underneath the bench. A small tray under the benchtop can hold the fastener supply and the tool when not in use.

6. If this tool does not work when it is first connected, do not try to make repairs. Call your Paslode representative immediately.



**DANGER**



**Air pressure at the tool must never exceed 120 psi.**

## TOOL OPERATION

### Depth of Drive Adjustment

(On tools equipped with this feature)



**WARNING**



**Keep the tool pointed in a safe direction. Disconnect the tool from the air supply and remove all fasteners.**

The depth of drive adjustment is made by adjusting the work contacting element. The lock nut is loosened to allow the element to be moved up or down. You will need a 3/8 inch open end or 5/32 inch hex socket wrench to make this adjustment.

If the tool is overdriving (the fastener head or crown is driven below the work surface), the work contacting element should be moved downward. If the fasteners stand up (the head or crown is not flush with the surface), the work contacting element should be moved up.

Adjust the work contacting element until the fastener head or crown depth meets job requirements.

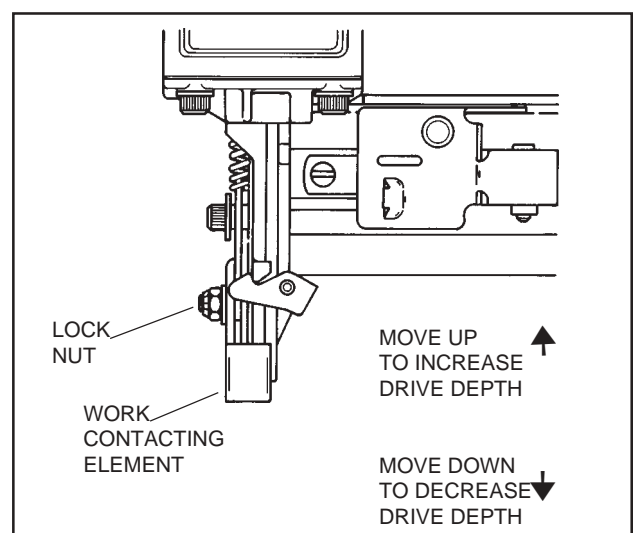



## TOOL OPERATION - continued

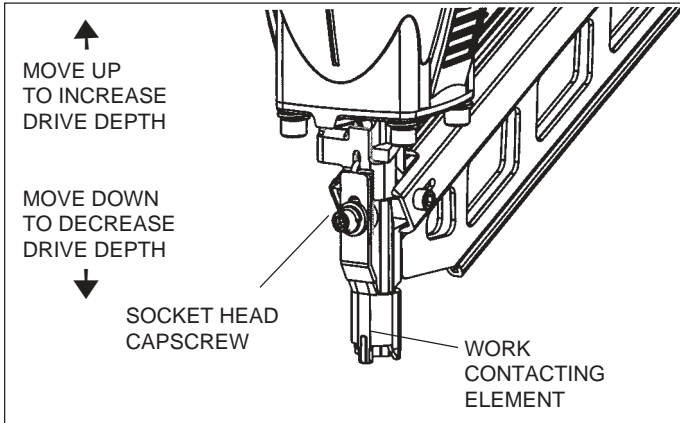

### Precision Placement Driving

- Grasp the tool handle firmly and hold the bottom of the work contacting element firmly against the workpiece until it is completely depressed.
- Squeeze the trigger to drive the fastener.
- Lift the tool from the workpiece.
- Repeat the procedure for the next fastener.

### Successive (Bounce) Driving

- Grasp the handle firmly.
- Squeeze the trigger and move the tool along the workpiece with a bouncing motion, depressing the work contacting element at the points where you want to insert a fastener.
- Keep the trigger depressed and continue to bounce the work contacting element against the workpiece, positioning the tool above as carefully as possible.
- When the desired number of fasteners have been driven, release the tool trigger to avoid unintentional fastener discharge.



**WARNING**

**Do not clamp or hold trigger with anything other than your hand.**

### Sequential Operation

The sequential operating kit prevents successive or "bounce" driving.

- Depress the work contacting element and hold it against the work surface before pulling the trigger.
- After each fastener is driven, completely release the trigger and lift the tool from the work surface.

## TOOL LOADING

### Staplers

**Step No. 1** – Pull back the rail follower until it latches at the end of the magazine. The rail cover will automatically open.

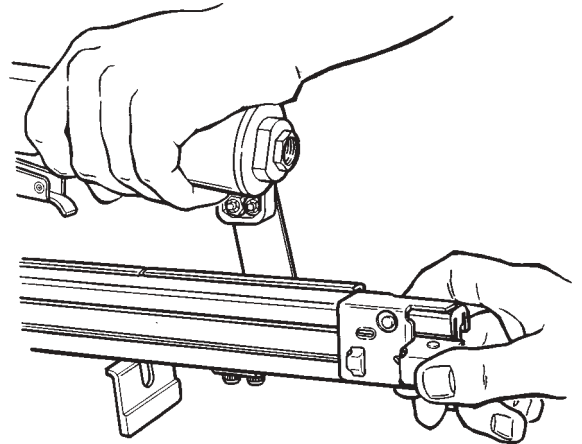

**Step No. 2** – Insert the fastener strip into the magazine rail.

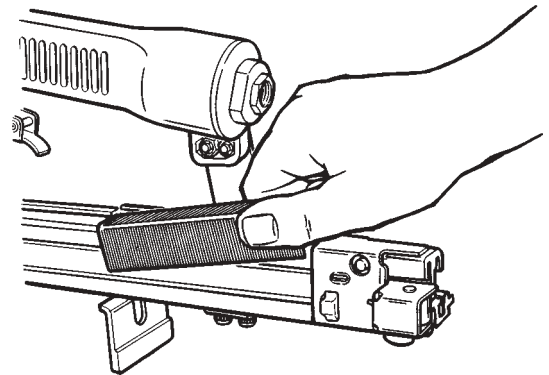

**Step No. 3** – Press the follower latch release button or unlatch the follower and slide the follower forward until it contacts the staple strip. The tool is now ready for use.

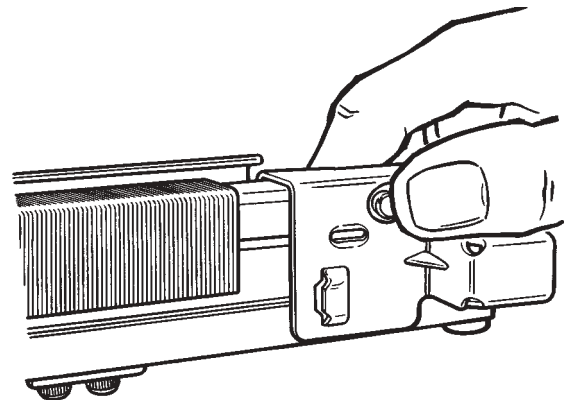



## Coil Nailers

**Step No. 1** – Grasp the nailer handle firmly with one hand and with the other hand unlatch the magazine cover clip. Swing the magazine door open.

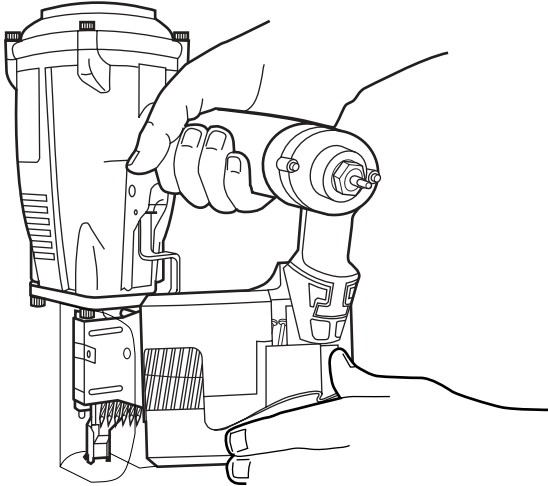

**Step No. 2** – Adjust the loading tray for nail length (if required) by depressing the button on the post and raising or lowering the tray to the desired position.

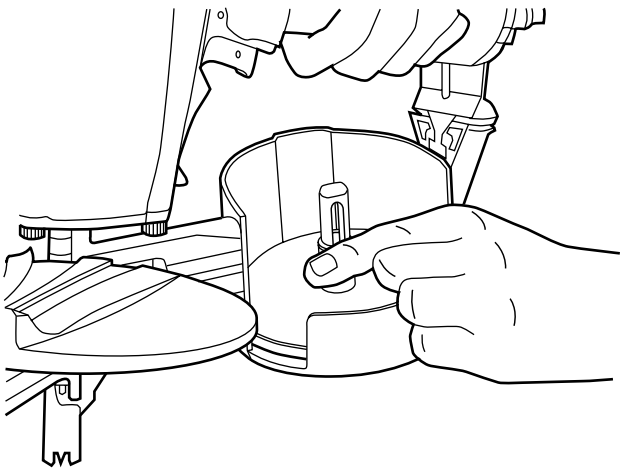

**Step No. 3** – Remove the retainer from a nail coil and place the nail coil in the magazine with the tips of the nails against the loading tray and with about 4 inches of coil unwound.

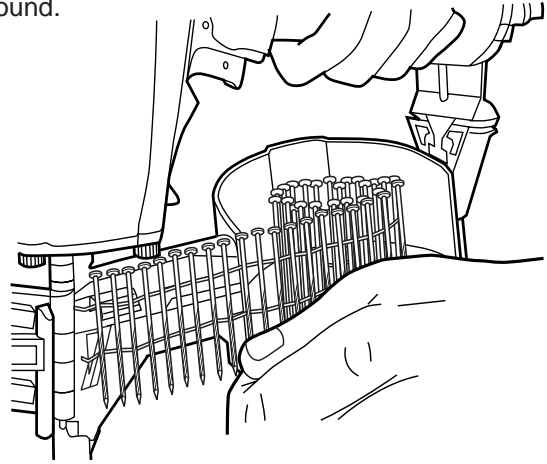

**Step No. 4** - Slide the free strip of nails along the top of the feeder body assembly and place the first nail between the feed claw and the locator.

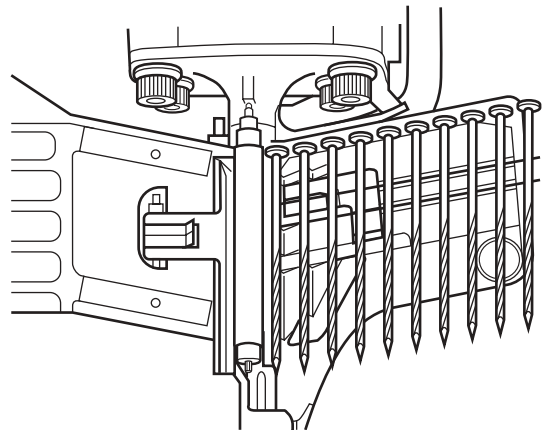

**Step No. 5** - Carefully close and latch the magazine door.

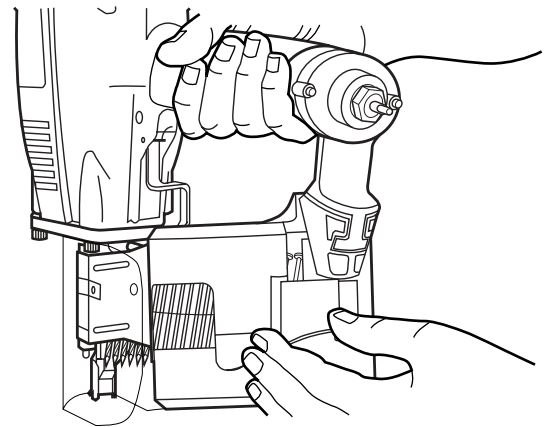

**Step No. 6** - Advance the first nail into driving position by cycling the tool once against a work surface. The nailer is now ready for use.

## PowerMaster Plus Series Strip Nailer

**Step No. 1** – Grasp the nailer handle firmly. Pull the magazine follower all the way to the rear of the magazine until it is latched into its loading position by the magazine latch.

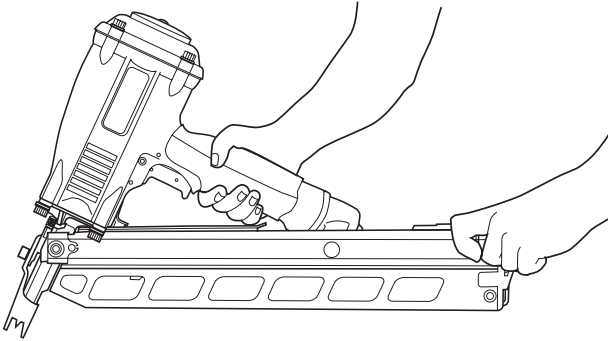

**Step No. 2** – Insert a strip of fasteners into the top of the magazine with the point of the nails facing the nose area.

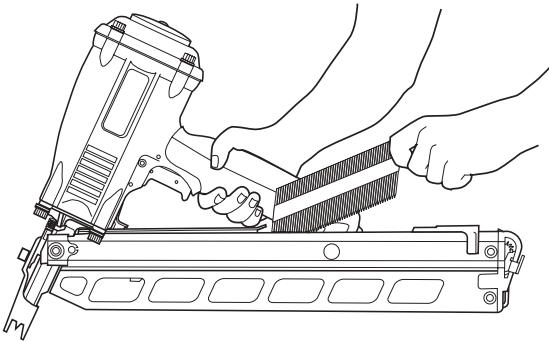

**Step No. 3** – Hold the follower firmly and press the follower latch. Slide the follower forward until it contacts the nails. The tool is now ready for use.  
NOTE: 5000S models have a follower release button.

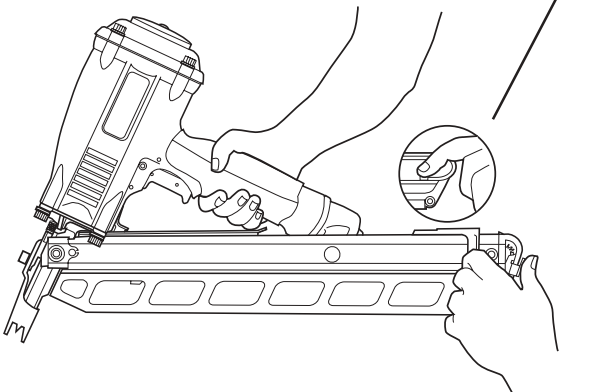

## T250-F16 Series Finish Nailer

**Step No. 1** – Grasp the nailer firmly with one hand.

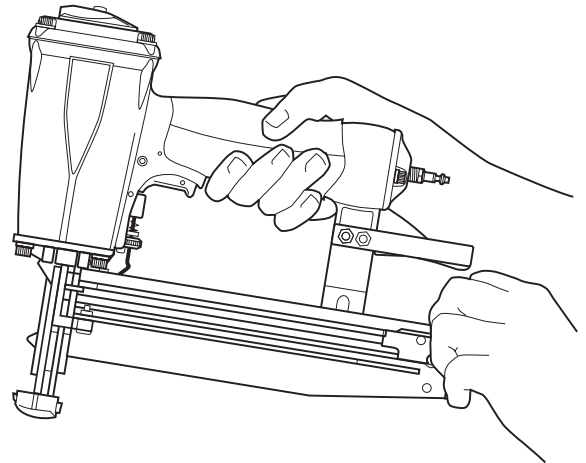

**Step No. 2** – Insert the strip with the point of the fastener facing down towards the bottom of the magazine.

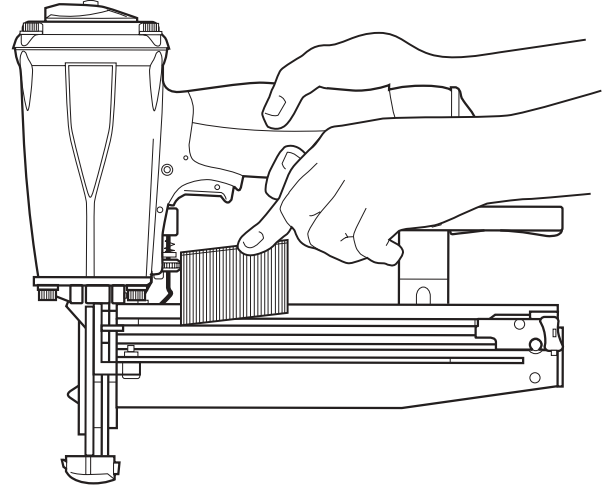

**Step No. 3** – Hold the follower firmly and press the follower latch. Slide the follower forward until it contacts the nails. The tool is now ready for use.

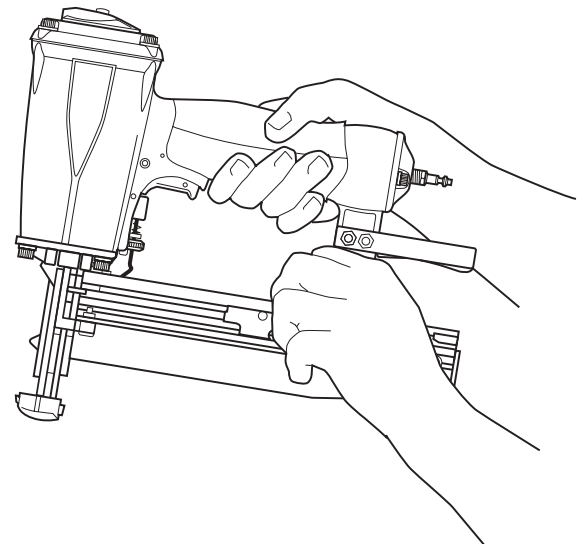

## 2000 Series Stapler

**Step No. 1** – Grasp the stapler firmly with one hand. Depending on the model, either squeeze the latch with your small finger or press it with your thumb. With your other hand, pull the magazine back towards you.

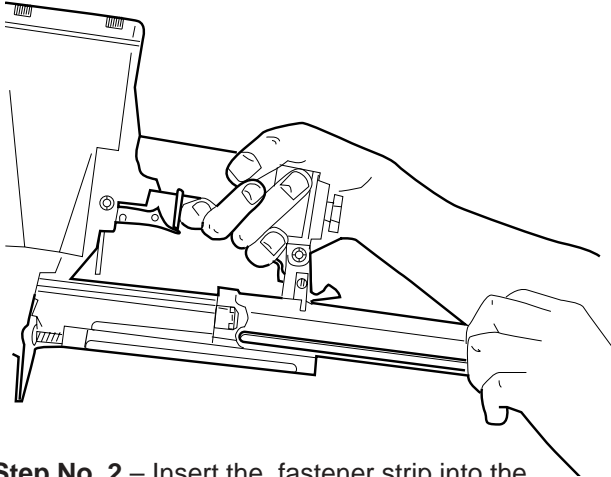

**Step No. 2** – Insert the fastener strip into the magazine rail.

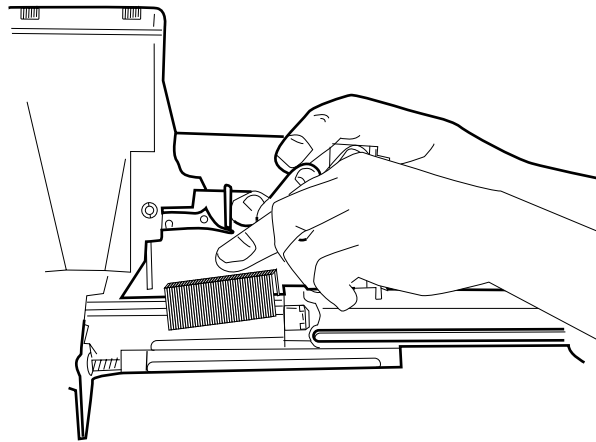

**Step No. 3** – Push the magazine firmly towards the front of the tool until it locks in place. The tool is now ready for use.

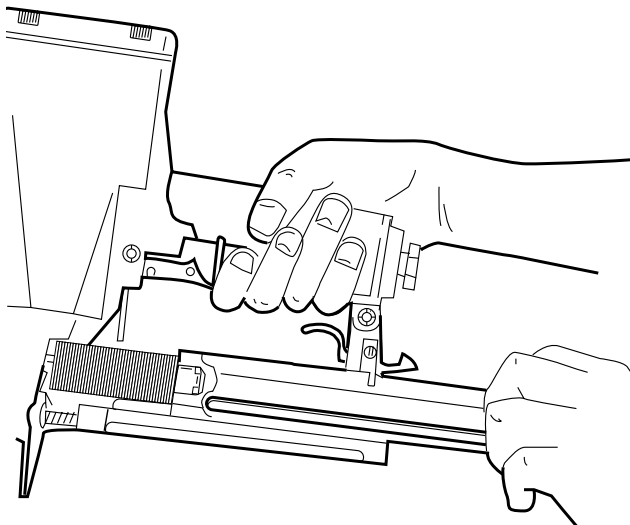

## 6000 Series Strip Nailer

**Step No. 1** – Grasp the nailer handle firmly. Pull the magazine follower all the way to the rear of the magazine and pivot it downward until it latches into the locked position.

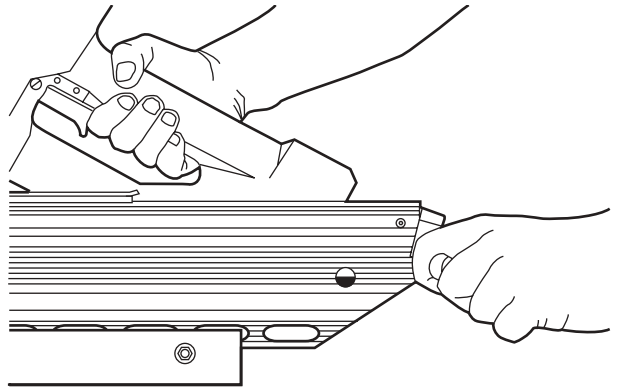

**Step No. 2** – Insert the a strip of fasteners into the top of the magazine with the point of the nails facing the nose area.

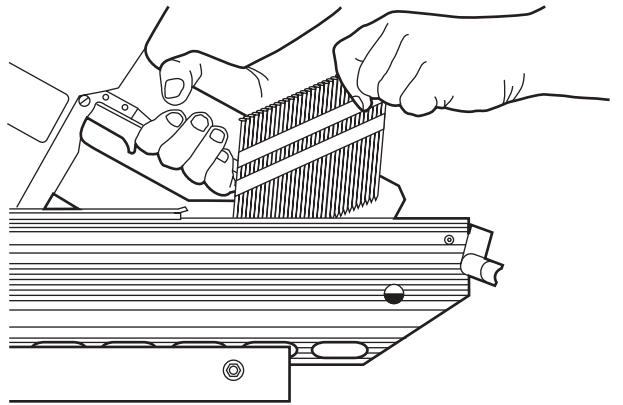

**Step No. 3** – Pivot the follower upward until it releases then slide the follower forward until it contacts the fasteners. The tool is now ready for use.

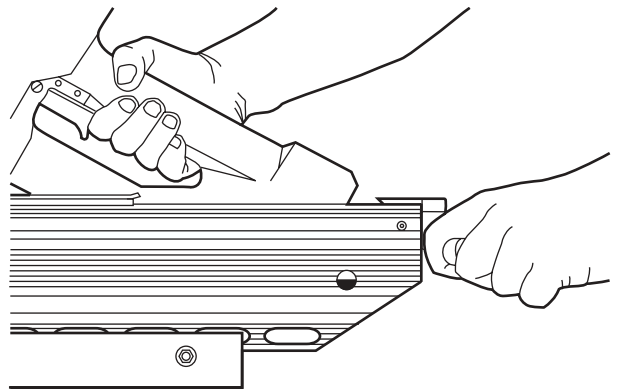

# MAINTENANCE

Paslode® tools are built for ease of maintenance. A few simple details will assure trouble-free operation and long tool life. Anyone who uses or maintains the tool must read the safety and maintenance instructions. Study the schematic drawing before starting any repairs on the tool.

Air-operated tools must be inspected periodically, and worn or broken parts must be replaced to keep the tool operating safely and efficiently. Also the items on the maintenance chart must be checked often.

## Cold Weather Care

When temperatures are below freezing, tools should be kept warm by any convenient, safe method. If this is not possible, the following procedure should be used to warm up the tools.

- Reduce the regulated air pressure to 30 psi.
- Remove all fasteners from the tool.
- Collect an air line and blank fire the tool. The reduced air pressure will be enough to free-fire the tool. Slow speed operation tends to warm up the moving parts. Slowing up the piston helps the bumper and the O-rings to become springy.

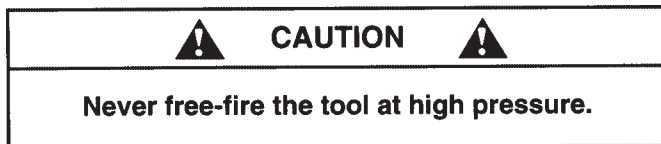

- Once the tool is warmed up, readjust the regulator to the proper working pressure and reload the tool.
- Tool operators working outdoors or in unheated areas in extremely cold temperatures should also:
  - Use Paslode pneumatic oil with antifreeze in the lubricator, Part No. 219090 (8oz.)
  - Once a week, depending on the amount of tool use, take the tool apart and wash away any sludge with degreaser cleaner (Paslode Part No. 219086) to keep the tool operating efficiently.

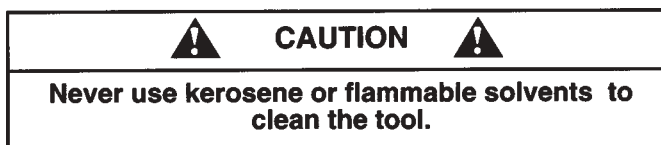

Cleaning the air-operated tools with solvents removes the thin coating of grease applied to the cylinder wall and O-rings at the factory. To replace this coating of grease, use Chemplex grease (Paslode Part No. 403734).

- Open the drain on the air compressor tank to drain any moisture at least daily in extremely cold or humid weather. A few ounces of anti-freeze in the tank will keep the air free of frost.

## Testing the Tool After Servicing

After replacing any part or parts, it is important to check the tool for proper operation. This ensures that the tool was put together correctly, is safe to use, and will perform the job properly.

- Ensure that all hardware is tight.
- Ensure that the work contacting element is installed correctly in relation to the trigger, and that both parts move freely.
- Ensure that the magazine is properly attached.
- Ensure that the required safety information on the tool is legible.
- Use only Paslode approved fasteners in the tool, and ensure that they are correct for the application.
- Ensure that a male air fitting is securely connected to the tool.
- Test the tool by driving fasteners into a workpiece identical to the tool's application.
- Check the tool for air leaks during testing and for the proper sequence of operation.
- Ensure that all fasteners are driven to the same depth and that the crown of the fastener is flush with the workpiece.

## Tool Lubrication



It is most important that the tool be properly lubricated by keeping the air line lubricator filled and correctly adjusted. Without proper lubrication the tool will not work properly and parts will wear prematurely.

Use the proper lubricant in the air line lubricator. The lubricator should be of low air flow or changing air flow type, and should be kept filled to the correct level. Use only Paslode recommended lubricants. Substitutes may harm the rubber compounds in the tools O-rings and other rubber parts. Paslode Part No. 219026 is a pneumatic lubricating oil specially made for pneumatic applications.

If a filter/regulator/lubricator is not installed on the air system, air operated tools should be lubricated at least once a day with 6 to 20 drops of oil, depending on the work environment, directly through the male fitting in the tool housing.

Most minor problems can be resolved quickly and easily using the maintenance table that follows. If problems persist, contact your Paslode dealer for assistance.



# MAINTENANCE - Continued

 <b>CAUTION</b> 
Disconnect the tool when performing repairs or clearing jams.

## MAINTENANCE TABLE

ACTION	WHY	HOW
Drain air line filter(daily).	Prevent accumulation of moisture and dirt.	Open manual petcock (most air supply systems have such a valve).
Keep lubricator filled.	Keep tool lubricated.	Fill with Paslode pneumatic tool lubricant. Part No. 219026.
Clean filter element-then blow air through filter in direction opposite to normal flow.	Prevent clogging of filter with dirt.	Wash with soap and water or follow manufacturers instructions.
Check that all screws on tool are tight.	Prevent air leakage and promote efficient operation.	Check screws daily.
Keep work contacting element working properly.	Promote operator safety and efficient tool operation.	Blow clean daily.
Keep magazine and feeder mechanism clean.	Prevent jamming of fasteners.	Blow clean daily.
Lubricate "O" rings that are replaced.	Assure long life and proper operation of tool.	Use Chemplex grease, Part No. 403734.
Use only Paslode replacement parts.	Keep tool operating efficiently and maintain Paslode tool warranty.	Order any replacement parts needed from Paslode Dealer.

# OPERATOR TROUBLESHOOTING

 <b>CAUTION</b> 
<p>Disconnect the tool when performing repairs or clearing jams.</p>

<b>PROBLEM</b>	<b>CORRECTIVE ACTION</b>
Fasteners will not drive completely into wood.	Adjust work contacting element (retract length).  Increase air pressure (do not exceed 120 psi).
Fasteners penetrate properly during normal operation, but won't drive fully at faster speeds.	Increase air flow to tool -- use larger air lines (3/8 inch ID minimum).
Fasteners drive too deeply into wood.	Adjust work contacting element (extend length).  Reduce air pressure.
Fastener jams in nose of tool.	Open front guide latch, release jammed fastener, and close latch securely.
Tools skips during operation - no fasteners are driven from time to time.	Check magazine for proper fasteners. Magazine follower should slide freely. Clean as needed to remove debris.  Make sure correct fasteners are being used. Use fasteners that meet Paslode® specifications only.  Increase air flow to tool -- use larger air lines (3/8 ID minimum).  Adjust work contacting element where available.
Tool operates, but no fasteners are driven.	Check magazine for proper fasteners. Fasteners should slide freely with no follower pressure.  Open front guide latch or loosen magazine knob and check for jams or debris in the nose area. Clear as necessary.  Increase air pressure (do not exceed 120psi).
Air leaks at cap when tool is connected to air.	Tighten capscrews.

# TOOL WARRANTY



An Illinois Tool Works Company  
888 Forest Edge Drive  
Vernon Hills, Illinois 60061

## TOOL WARRANTY AND LIMITATIONS

Paslode warrants that newly purchased power fastening tools parts and accessories will be free from defects in material and workmanship (excluding wear parts) for the period shown below, after the date of delivery to the original user.

### 90-DAY LIMITED WARRANTY

A 90-day warranty will apply to all parts, except those which are specifically covered by an extended warranty.

### EXTENDED LIMITED WARRANTY FOR ON SITE CONSTRUCTION APPLICATIONS

A one year warranty will apply to all housing and cap assembly castings. A six month warranty will apply to all magazines parts.

### NORMAL WEARING PARTS

The following parts are considered normal wearing parts and are not under warranty:

- Bumper
- Drive Blades
- "O" Rings
- Piston Rings

### WARRANTY STATEMENT

Paslode's sole liability hereunder will be to replace any part or accessory which proves to be defective within the specific time period. Any replacement part or accessory provided in accordance with this warranty will carry a warranty for the balance of the period of warranty applicable to the part it replaces.

This warranty is void as to any tool which has been subjected to misuse, abuse, accidental or intentional damage, used with fasteners not meeting Paslode specification, size, or quality, improperly maintained, repaired with other than genuine Paslode replacement parts, damaged in transit or handling, or which, in Paslode's opinion, has been altered or repaired in a way that affects or detracts from the performance of the tool.

PASLODE MAKES NO WARRANTY, EXPRESSED OR IMPLIED, RELATING TO MERCHANTABILITY, FITNESS, OR OTHERWISE, EXCEPT AS STATED ABOVE, and Paslode's liability AS STATED ABOVE AND AS ASSUMED ABOVE is in lieu of all other warranties arising out of, or in connection with, the use and performance of the tool, except to the extent otherwise provided for by applicable law. PASLODE SHALL IN NO EVENT BE LIABLE FOR ANY DIRECT, INDIRECT, OR CONSEQUENTIAL DAMAGES, INCLUDING, BUT NOT LIMITED TO, DAMAGES WHICH MAY ARISE FROM LOSS OF ANTICIPATED PROFITS OR PRODUCTION, SPOILAGE OF MATERIALS, INCREASED COST OF OPERATION, OR OTHERWISE.

Paslode reserves the right to change specifications, equipment, or designs at any time without notice and without incurring obligation.